

BASE

FREESTANDING FIRE TABLE



This multi-function table gives you the best of both worlds – a coffee table and fire pit combined. Our Triple Fuel Advantage (NG/LP/Ethanol) combined with Fluid Concrete Technology delivers an unmatched fire solution suitable for indoor and outdoor settings.

Optional Fire Screens

Pair with a toughened glass fire screen, which stabilises the flame in windy conditions.

Functional Table Space

Standing 340mm [13"] tall Base features space for accommodating food and drinkware.

Black Glass Charcoal

The Black Glass Charcoal is made from high-quality tempered glass and has been designed to withstand harsh weather and temperatures of up to 1300°F/700°C without ever cracking, or losing its color or shape. Black Glass Charcoal does not emit any toxic fumes, smoke, or ash so it is extremely easy to maintain and clean.

Colors

Our concrete models come in three different colors: Natural, Graphite and Bone.

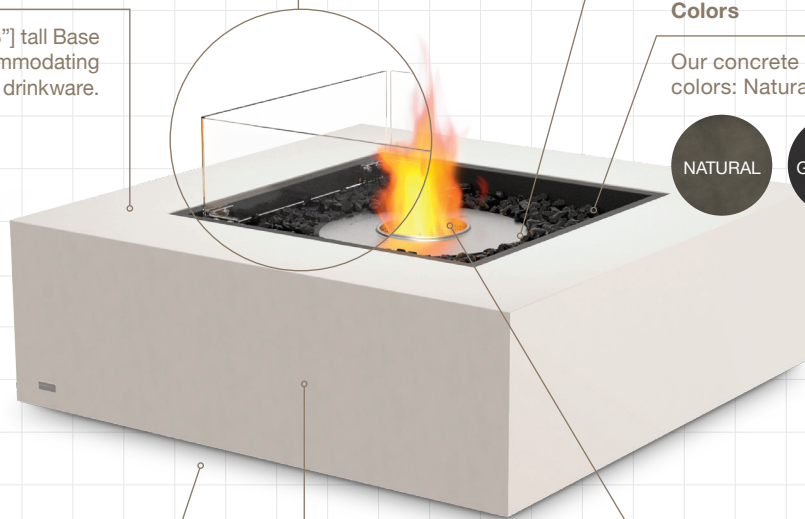
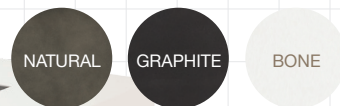

Versatile and Re-locatable

When you select Bioethanol or Liquid Propane as your fuel source you'll never be tied down! With zero hard utility connections, relocating your fire is a breeze. Entertain on your own terms with EcoSmart Fire.

Fluid Concrete Technology

Featuring a stain and impact-resistant barrier that protects the concrete from environmental weathering – even under extreme conditions and long UV exposure.

Triple Fuel Advantage



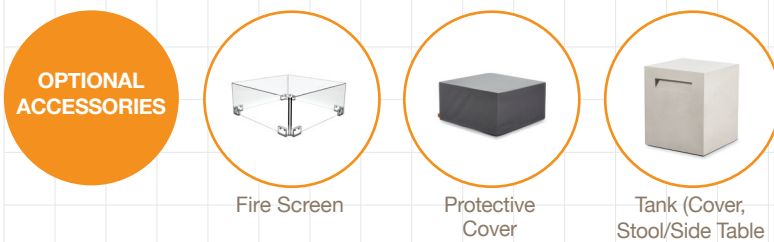



Choose between plumbed natural gas, readily available propane, or our eco-friendly bioethanol fuel system. We make it easy for you to achieve exactly what you want, for exactly where you want it.



Disclaimer: All product specifications and data are subject to change without notice and believed to be correct at the time of publication. MAD Design Group (MDG), its affiliates, agents, and employees, and all persons acting on its or their behalf (collectively, "MAD Design Group"), disclaim any and all liability for any errors, inaccuracies or incompleteness contained herein or in any other disclosure relating to any product. MDG disclaims any and all liability arising out of the use or application of any product described herein or of any information provided herein to the maximum extent permitted by law. The product specifications do not expand or otherwise modify MDG's terms and conditions of purchase, including but not limited to the warranty expressed therein, which apply to these products. No license, express or implied, by estoppel or otherwise, to any intellectual property rights is granted by this document or by any conduct of MDG. Customers using or selling MDG products not expressly indicated for use in such applications do so entirely at their own risk and agree to fully indemnify MDG for any damages arising or resulting from such use or sale. Please contact authorized personnel from MDG to obtain written terms and conditions regarding products designed for such applications. Images are indicative only.

BASE



Application	Outdoor		
Materials	Fluid Concrete Technology, Grade 304 Stainless Steel, Included Black Glass Charcoal		
Approx Weight	66kg [145lbs] Weight includes burner and black glass charcoal.		
Colors & SKU's	LP/NG	 Natural	ESF.3.O.BAS.NA.G
		 Bone	ESF.3.O.BAS.BO.G
		 Graphite	ESF.3.O.BAS.GH.G
	Bioethanol	 Natural	ESF.3.O.BAS.NA.E
		 Bone	ESF.3.O.BAS.BO.E
		 Graphite	ESF.3.O.BAS.GH.E
Optional Accessories	Fire Screen, Protective Cover, Tank (tank cover or stool/side table)		

FUEL OPTIONS	BTU/HR	BURN HOURS*
Liquid Propane	55,000	8 - 20
Natural Gas	55,000	Unlimited
Bioethanol	20,000	7 - 11

* These Values are Indicative only.

This model comes with fixing brackets for permanently locating into a fixed position

LP/NG Burners are UL/ULC Listed.
Bioethanol Burner is UL Listed.

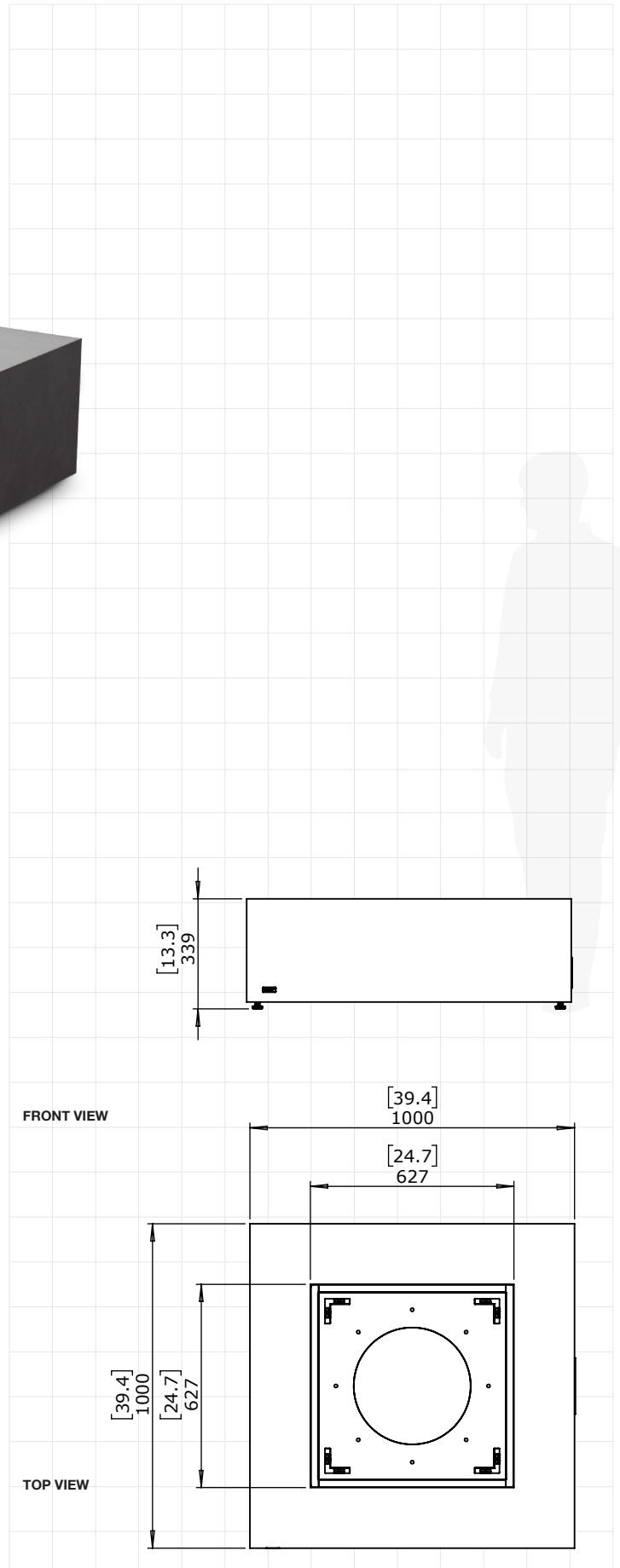

FOR MORE INFORMATION PLEASE REFERENCE THE CLEARANCE & INSTALLATION MANUAL

Disclaimer: All product specifications and data are subject to change without notice and believed to be correct at the time of publication. MAD Design Group (MDG), its affiliates, agents, and employees, and all persons acting on its or their behalf (collectively, "MAD Design Group"), disclaim any and all liability for any errors, inaccuracies or incompleteness contained herein or in any other disclosure relating to any product. MDG disclaims any and all liability arising out of the use or application of any product described herein or of any information provided herein to the maximum extent permitted by law. The product specifications do not expand or otherwise modify MDG's terms and conditions of purchase, including but not limited to the warranty expressed therein, which apply to these products. No license, express or implied, by estoppel or otherwise, to any intellectual property rights is granted by this document or by any conduct of MDG. Customers using or selling MDG products not expressly indicated for use in such applications do so entirely at their own risk and agree to fully indemnify MDG for any damages arising or resulting from such use or sale. Please contact authorized personnel from MDG to obtain written terms and conditions regarding products designed for such applications. Images are indicative only.